

exposure
high fidelity engineering
since 1974

INTEGRATED
AMPLIFIER XXXV

Quick Start
Manual

Thank you for buying the Exposure Integrated Amplifier XXXV. Designed with the utmost care and precision to provide you with all you need for pure listening pleasure.

Before you start

Contents:



Exposure Integrated Amplifier XXXV



Mains cable

HS-101 Exposure System remote control (batteries included)



Ensure your unit is switched off and that the volume control knob is at its minimum.



Please note that your Exposure Integrated Amplifier XXXV may take up to 48 hours to "run-in" before reaching its optimal performance. Each subsequent "run-in" will then take about 30 minutes.



The Exposure Integrated Amplifier XXXV is equipped with a heat sensor which will automatically switch off the power amplifier section when an abnormally high temperature is reached. To reset the output, switch off the Amplifier and allow it to cool for 10 to 15 minutes.

1 Installation

Exposure Integrated Amplifier XXXV: Front View

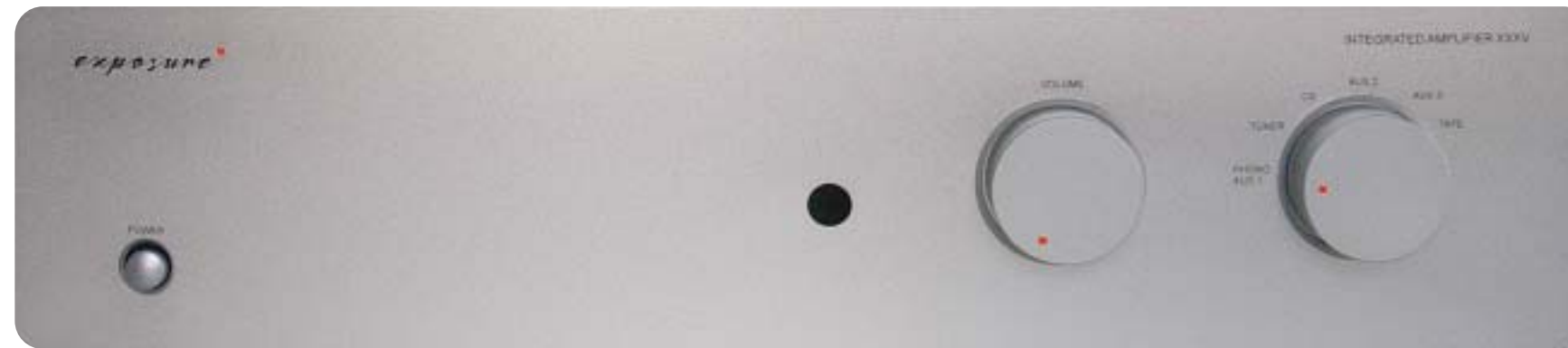

a) Turn volume control to minimum before connecting or disconnecting any cables.



b) Connect the mains cable to the IEC mains input socket.



c) Connect to the mains outlet on the wall. DO NOT switch on until all input and output connections are made.

2 CD Player/Tuner/Tape/DVD Connection

The Exposure Integrated Amplifier XXXV is fitted with six-line level RCA Phono inputs, suitable for connection of CD players, tuners and tape or DVD players.

Exposure Integrated Amplifier XXXV: Back View

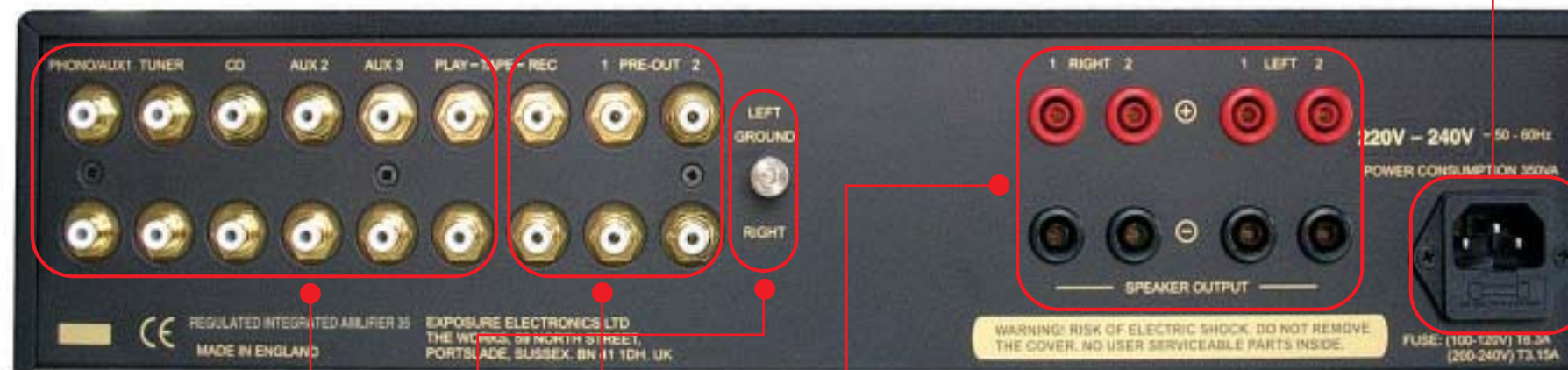

Input

- Connect RCA Phono cables from source component (CD Player/Tuner/Tape/Disc Recorder) to the respective input.
- Ensure left and right channels are connected correctly (Right channel is marked in red).
- The tape input is labeled TAPE PLAY.

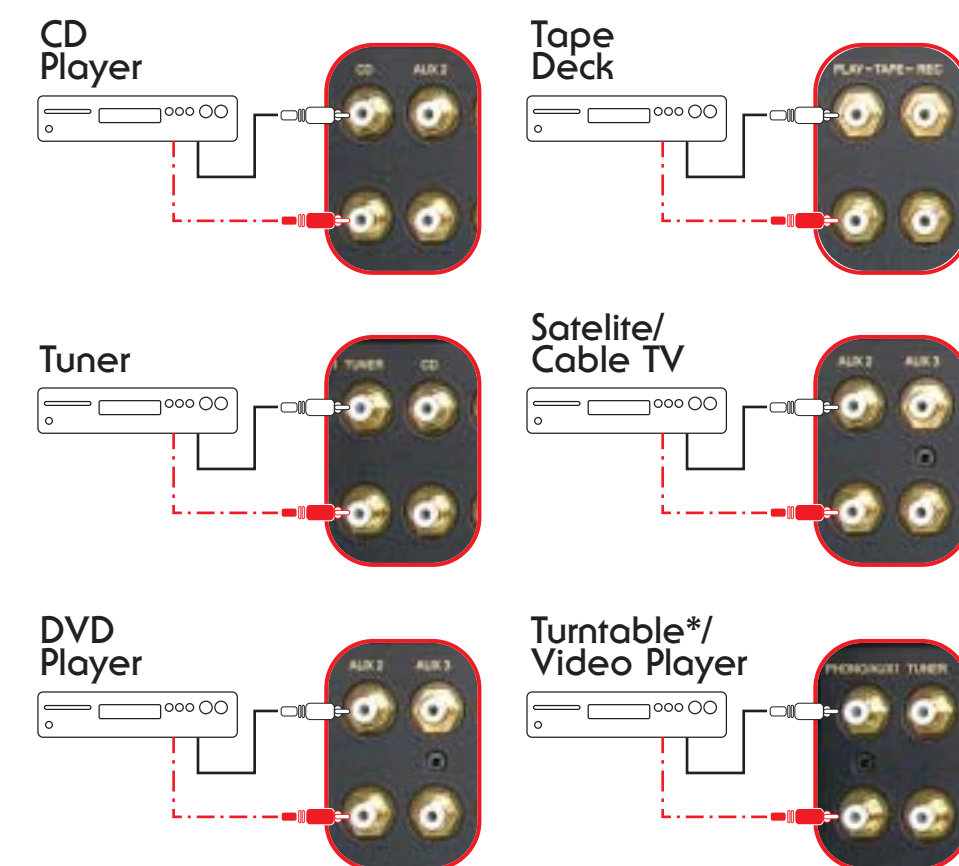

* Turntable connection requires the installation of an optional MM or MC Phono Card.

Output

- TAPE REC** provides line level output signals for recording.
- PRE OUT** provides left and right channel output signals appropriate for connection to Exposure Dual Mono Power Amplifier XXVIII (for future proof upgrade).

3 Loudspeaker Connection

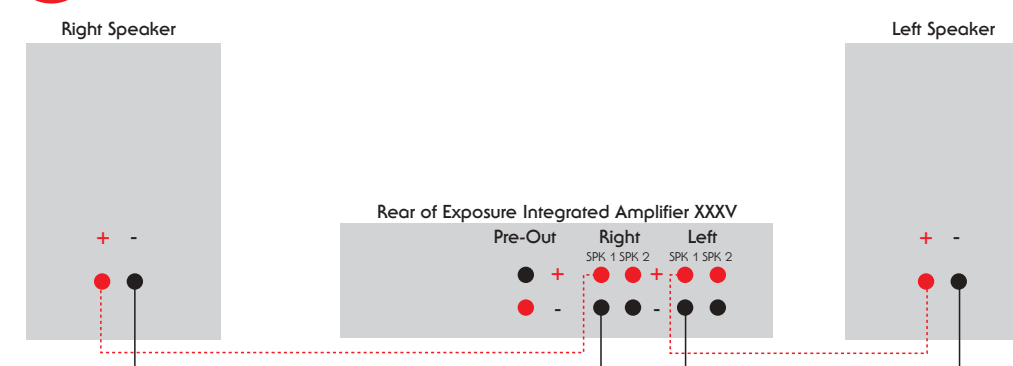

- Connect left and right loudspeakers to corresponding left and right speaker outputs on amplifier.
- Connect (+) terminal of loudspeaker to (+) terminal of the amplifier.
- Connect (-) terminal of loudspeaker to (-) terminal of the amplifier.

Bi-wired connection

Bi-wiring may provide a useful gain in subjective performance. Should you choose this option, please refer to the "Extended Set-Up" instructions overleaf.

Bi-amping of Loudspeakers

Bi-amping of loudspeakers using an Integrated XXXV and a Dual Mono Power Amplifier XXVIII provides a useful gain in subjective performance. For this operation, please refer to the "Extended Set-Up" instructions overleaf.

4 Operation



a) Turn amplifier volume control to minimum.



b) Press power switch. The LED power indicator will light up. The amplifier output relay will activate after a 6-second delay.



c) Without playing any CD/Tape/Disc, turn the volume control knob slowly clockwise to around 30%. It is normal to hear a faint hiss.



d) Turn the source selection knob to select a live source component. (CD Player/Tuner/Tape/DVD/etc)

e) Audio should now be heard when the source component is played.

5 Remote Control

The source selection knobs will rotate to match selections made on remote control.



Red Button

Mutes the volume output to minimum. Press again to reactivate volume output to its previous level.

Green Buttons

Increase/decrease the volume. Indicator light will flash as volume is adjusted.

Black Buttons

Select input sources. Indicator light will flash on the Integrated Amplifier as the selector switch rotates.

Installation Notes

- Installation of a MC or MM Phono Module: For details, please refer to the "Extended Set-Up" section overleaf or contact your dealer.
- AUX 1 input can be converted to accept moving coil or moving magnet cartridge signals through the addition of an internal module. Please contact your dealer for more information.
- A ground terminal is provided for connection to a turntable arm wire or RCA ground only.

Exposure Integrated Amplifier XXXV Extended Set-Up

Although the Exposure Integrated Amplifier XXXV is able to drive almost any loudspeaker system, the best results will most likely be achieved with speakers rated at 8 Ohms. While the Exposure Integrated Amplifier XXXV is compatible with most types of loudspeaker cables, the type of cables used can influence the subjective performance of your system.

Please ask your Exposure dealer for advice on bi-amping, loudspeaker cable compatibility and how to get the best from your Exposure Integrated Amplifier XXXV.

Note: Exposure Integrated Amplifier XXXV is internally protected against damage from short circuits. However, no such protection is infallible, and damage may occur if positive and negative speaker cables are inadvertently connected together.

Bi-wiring

The Exposure Integrated Amplifier XXXV is fitted with two sets of 4mm loudspeaker connection output sockets for bi-wired connection of loudspeakers. Another pair of speaker wires is required for this operation for each loudspeaker.

1. Ensure that the links at the speaker terminals between the high frequency and the low frequency are removed on both loudspeakers.
2. Follow the diagram below for connecting a pair of loudspeakers in bi-wiring mode.

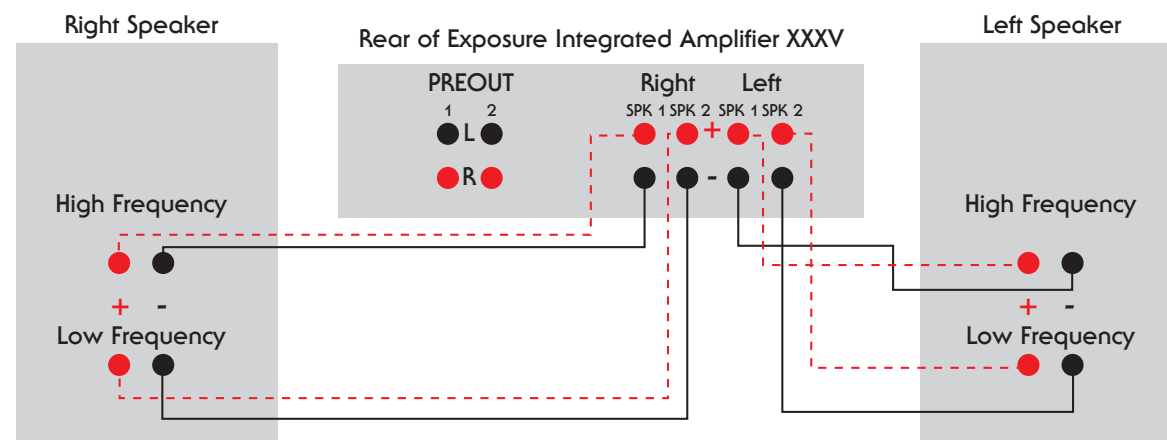

Connecting a pair of loudspeakers in bi-wiring mode

Bi-amping of Loudspeakers

Bi-amping of suitable loudspeakers using an Integrated XXXV and a Dual Mono Power Amplifier XXVIII provides a useful gain in subjective performance. The Integrated Amplifier is used to drive the treble units and the Power Amplifier is used to drive the bass units through the loudspeakers split crossover with the joining links removed.

1. Check your loudspeaker user manual for the wiring connections.
2. Follow diagram below for connecting a pair of loudspeakers in bi-amping mode.

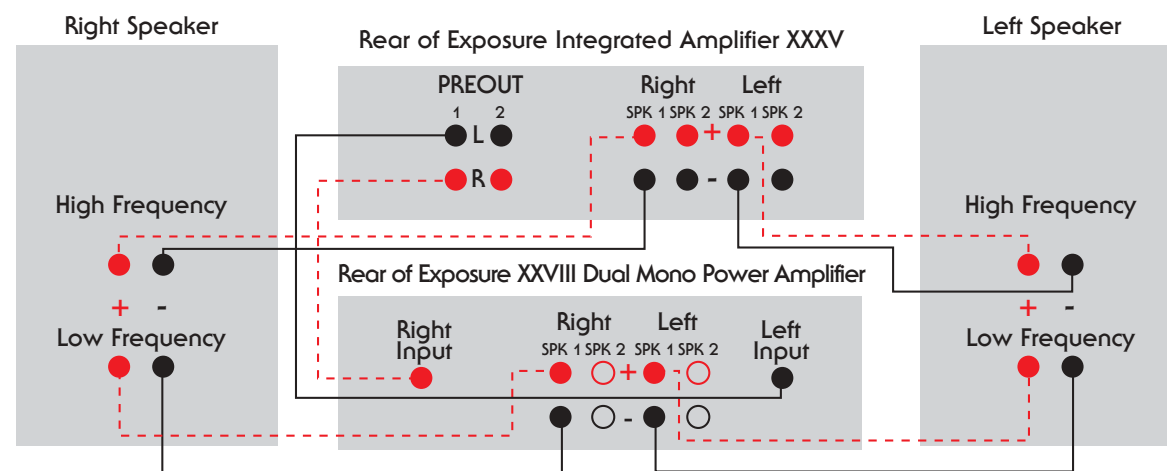

Connecting a pair of loudspeakers in bi-amping mode

Installation of a MC or MM Phono Module

This is best carried out by your dealer. However, if you wish to attempt installation yourself:

1. Switch off the unit.
2. Remove the mains lead from the wall and the IEC socket.
3. Remove the four cover screws.
4. Slide the cover back about 2 cm until it is free to move upwards to reveal the main circuit board.
5. Remove the small jumper board that is fitted on the right hand side at the back.
6. Observe the position of the plug on the phono module and carefully plug it in, ensuring that all of the pins are inserted correctly into their connectors.
7. Fit the three M3 x 6mm bolts that are supplied with the phono module.
8. Replace the cover and screws.

Safety

Incorrect installation or inappropriate use of the Exposure Integrated Amplifier XXXV may result in injury due to electrical shock.

- Ensure that the voltage rating on the rear panel of this unit matches that of your local mains supply. *
 - Ensure that the mains cable and plug supplied with this unit is also correct. (Contact your dealer immediately if this is not the case)
 - This unit is protected by a mains fuse, which is accessible as part of the IEC socket on the rear panel.
 - Fuse replacement specifications:
220/240V units T4A fuse
110/120V units T8A fuse
 - Protect unit against all forms of liquid. Never expose unit to dripping or splashing, or place objects filled with water, such as vases, on the unit.
 - Unplug unit from mains when not in use for prolonged periods.
 - Do not open this unit – there are NO user serviceable parts inside (except to install or change a phono card).
 - Reduce the volume control to minimum before turning this unit on or off.
 - Ensure that this unit is switched off when connecting or disconnecting speaker and interconnect cables.
- * Contact Exposure Electronics for advice on moving your equipment to another country or territory.

Caution

For a long and trouble free life of your Exposure Integrated Amplifier XXXV, please ensure the following:

- Do not short circuit the speaker terminals.
- Do not remove the cover of the Integrated Amplifier or dismantle the case (except to install or change a phono card).
- Protect unit against all forms of liquid. Never expose unit to dripping or splashing, or place objects filled with water, such as vases, on the unit.
- Do not operate the Integrated Amplifier in damp environment or allow liquids to enter the unit.
- Do not attempt to bypass the mains fuse or replace the fuse with one of a different specification.
- Do not place the Integrated Amplifier in a position which restricts cooling airflow around its case.
- Do not use abrasive or solvent based cleaning fluids on the Integrated Amplifier's case.

Failure to observe these precautionary measures may void your warranty.

Technical Specifications

Power Output (2 channels):	80 Watts per channel at 1KHz into 8 Ohms.
Power Output (2 channels):	160 Watts at 1KHz into 4 Ohms.
Input Impedance:	19K Ohms minimum (line input)
Frequency Response:	20Hz - 20 KHz ± 0.5 dB
Total Harmonic Distortion:	<0.015% at rated output, ref 1 KHz.
Signal to Noise:	>110 dB, ref rated output
Channel Separation:	>70dB, 20Hz - 20KHz
Mains Supply:	110/120V or 220/240V, 50/60Hz (factory set)
Power Consumption:	<400VA 8 Ohms load both channels driven.
Dimensions (H x W x D):	115 mm x 440 mm x 300 mm
Nett Weight (unpacked):	11.5 kg
Gross Weight (Packed):	13.5 kg

Exposure Warranty Policy

1. The Exposure warranty entitles you to FREE repair of this unit for the first three (3) years from the date of purchase.
2. This warranty is valid only if the unit is purchased from an authorised Exposure dealer, registered with the authorised agent in your country of residence and issued with a recognised warranty card.
3. The agent accepts no responsibility for defects arising from accident, misuse, abuse, wear and tear, neglect or through unauthorised adjustment and/or repair or replacement of any components, nor will they accept responsibility for damage or loss occurring during transit to or from the person making a claim under the warranty.
4. The Exposure warranty covers:
 - Parts and labour costs for three (3) years from the date of purchase. Please retain your original receipt as proof of purchase and purchase date. The guarantee is extended only to the original purchaser and is not transferable.

When making claims under this warranty:

1. The equipment should be suitably packed and returned to the dealer from whom it was purchased, or directly to the local distributor, together with proof of purchase or a copy of the dated sales receipt.
2. If necessary the unit should be sent carriage pre-paid by a reputable carrier – NOT by post.
3. No responsibility is accepted for the unit whilst in transit to the dealer or agent, and customers are advised to insure the unit against loss or damage whilst in transit.
4. The warranty card MUST be produced when making claims against this guarantee.
5. Any tampering or alteration made to the warranty card or to the serial number on the equipment will invalidate the warranty.
6. The dealer or the agent shall notify the customer when the repairs have been completed. The customer must claim the goods within fourteen days from the date of notice, failing which, the Company reserves the right to impose storage charges.
7. The Company reserves the right to dispose of the equipment after 90 days from the date of notice in a manner that it sees fit and without compensation to the customer.