

exposure
high fidelity engineering
since 1974

DUAL MONO POWER AMPLIFIER XXVIII

Quick Start Manual

Thank you for buying the Exposure Dual Mono Power Amplifier XXVIII, designed to deliver optimal performance to enhance your musical enjoyment.

Before you start

Contents:

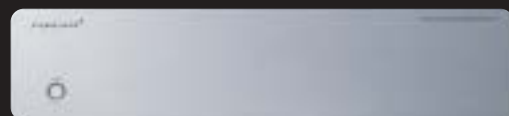

Exposure Dual Mono Power Amplifier XXVIII

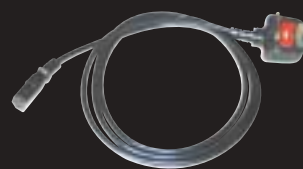

Mains cable



Ensure that the unit is switched off and the volume control on the system's integrated amp or pre-amp is set at its minimum.



Please note that your Exposure Dual Mono Power Amplifier XXVIII may take up to 48 hours to "run-in" before reaching its optimal performance. Each subsequent "run-in" will then take about 20 minutes.

1 Installation

The Exposure Dual Mono Power Amplifier XXVIII: Front View



a) Connect the mains cable to the IEC mains input socket.



b) Connect to the mains outlet on the wall. DO NOT switch on until all input and output connections are made.

2 Pre-Amp/Integrated Amp Connection

Your Exposure Dual Mono Power Amplifier XXVIII Amplifier is equipped with a stereo pair of high level RCA phono sockets.

The Exposure Dual Mono Power Amplifier XXVIII: Back View



If your Exposure Dual Mono Power Amplifier XXVIII Amplifier is used with a matching Exposure XXIII Pre-Amplifier:

- Connect cables from XLR sockets to the PRE-OUT sockets of the pre-amp.
- Ensure left and right channels are connected correctly.

If your Exposure Dual Mono Power Amplifier XXVIII Amplifier is used with an integrated amp:

- Connect cables from RCA Phono inputs of power amp to the PRE-OUT sockets of pre-amp/integrated amp.
- Ensure left and right channels are connected correctly. (Right channel is marked in red)

3 Loudspeaker Connection

- Connect the left and right loudspeakers to the corresponding left and right speaker outputs of your Exposure Dual Mono Power Amplifier XXVIII.
- Connect the (+) terminal of the loudspeaker to the (+) terminal of the power amp.
- Connect the (-) terminal of the loudspeaker to the (-) terminal of the power amp.

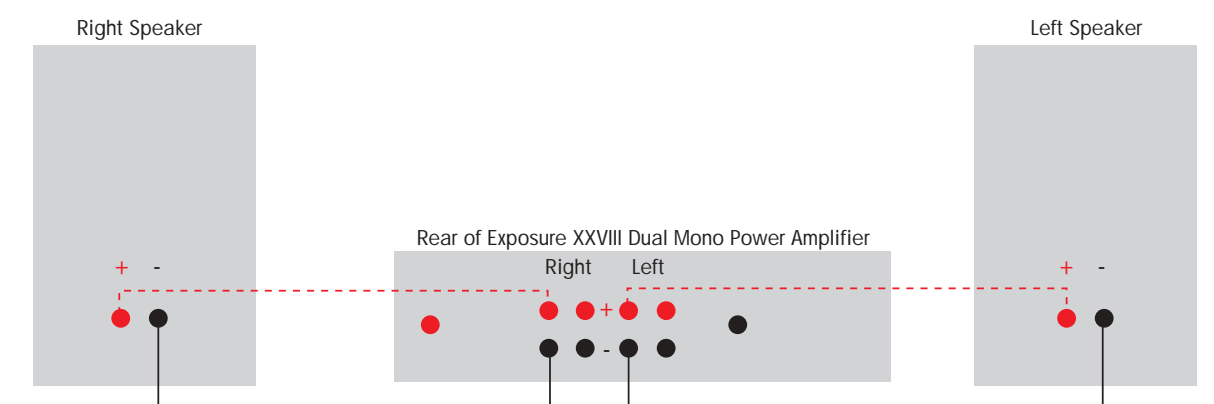

4 Operation



a) Turn amplifier volume control to minimum.



b) Connect the mains plug to the mains wall socket.



c) Press power switch of pre-amplifier.



d) Press power switch of power amplifier. The LED power indicator will light up.



e) Without playing any CD/Tape/Disc, turn the volume control knob slowly clockwise to around 30%. You should only hear a faint hiss.

For details on bi-wiring and/or bi-amping of loudspeakers, please refer to the Extended Set-up section overleaf.

Exposure Dual Mono Power Amplifier XXVIII: Extended Set-up

Bi-wiring of Loudspeakers

The Exposure Dual Mono Power Amplifier XXVIII is fitted with two sets of 4mm sockets for bi-wired connection to loudspeakers.

Bi-wiring may provide a useful gain in subjective performance. Please refer to the manufacturer of your loudspeakers for advice on the practicality and potential benefits of bi-wiring.

Loudspeaker Compatibility

Although the Exposure Dual Mono Power Amplifier XXVIII is able to drive almost any loudspeaker system, the best results will most likely be achieved with speakers rated at 8 Ohms.

Speaker Cable Compatibility

While the Exposure Dual Mono Power Amplifier XXVIII is compatible with most types of loudspeaker cables (except for low inductance types), the type of cable used can influence the sonic performance of your system. Please ask your Exposure dealer for advice on loudspeaker cable compatibility and how to get the best from your Exposure Dual Mono Power Amplifier XXVIII.

Note: The Exposure Dual Mono Power Amplifier XXVIII is internally protected against damage from short circuits. However, no such protection is infallible, and damage may occur if positive and negative speaker cables are inadvertently connected together.

Bi-amping of Loudspeakers

Bi-amping of loudspeakers provides a useful gain in subjective performance. A pre-amplifier, like the Exposure Pre-amplifier XXIII and two units of Exposure Dual Mono Power Amplifier XXVIII are required for bi-amping of suitable loudspeakers through its split crossover.

Please check your loudspeaker's user manual for wiring connections. Your dealer or local distributor will be able to offer further advice.

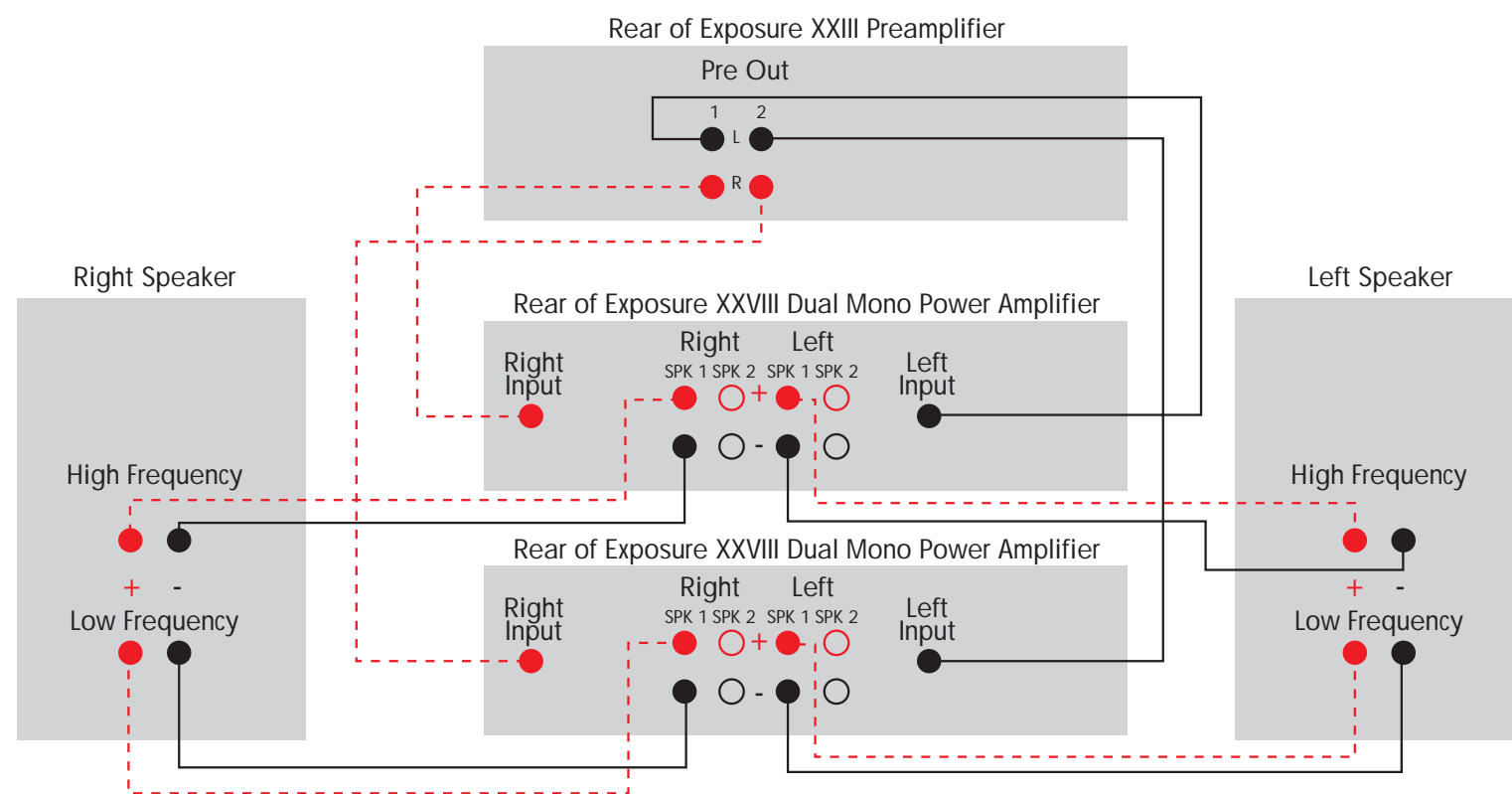

Safety

Incorrect installation or inappropriate use of the Exposure Dual Mono Power Amplifier XXVIII may result in injury due to electric shock.

- Ensure that the voltage rating on the rear panel of this unit matches that of your local mains supply. *
 - Ensure that the mains cable and plug supplied with this unit is also correct. (Contact your dealer immediately if this is not the case)
 - This unit is protected by a mains fuse, which is accessible as part of the IEC socket on the rear panel.
 - Fuse replacement specifications:
220/240V units T3.15A fuse
110/120V units T6.3A fuse
 - Protect unit against all forms of liquid. Never expose unit to dripping or splashing, or place objects filled with water, such as vases, on the unit.
 - Unplug unit from mains when not in use for prolonged periods.
 - Do not open this unit – there are NO user serviceable parts inside.
 - Reduce the volume control on the system's integrated or pre amp to minimum before turning this unit on or off. The Exposure Dual Mono Power Amplifier XXVIII may generate a faint "thump" or "whistle" from the loudspeakers when switching on or off. This is normal and does not indicate any cause for concern.
 - Ensure that this unit is switched off when connecting or disconnecting speaker and interconnect cables.
- * Contact Exposure Electronics for advice on moving your equipment to another country or territory.

Caution

For a long and trouble-free life of your Exposure Dual Mono Power Amplifier XXVIII, please ensure the following:

- Do not short circuit the speaker terminals.
- Do not remove the cover of the Power Amplifier or dismantle the case.
- Protect unit against all forms of liquid. Never expose unit to dripping or splashing, or place objects filled with water, such as vases, on the unit.
- Do not operate the Power Amplifier in a damp environment or allow liquids to enter the unit.
- Do not attempt to bypass the mains fuse or replace the fuse with one of a different specification.
- Do not place the Power Amplifier in a position which restricts cooling airflow around its case.
- Do not use abrasive or solvent-based cleaning fluids on the Power Amplifier's case.

Failure to observe these precautionary measures may void your warranty.

Technical Specifications

Power Output (Stereo):	70 Watts per channel, 8 Ohms.
Input Impedance:	18K ohms @ 1 KHz
Frequency Response:	-3dB @ 3Hz and 62KHz, ref 1 KHz
Total Harmonic Distortion:	<0.02% at rated power, 1 KHz
Signal to Noise Ratio:	>110 dB A weighted, ref rated output
Channel Separation:	>70dB, 20Hz – 20KHz (typically > 95dB @ 1KHz)
Mains Supply:	110/120V or 220/240V, 50/60Hz (factory set)
Power Consumption:	<350VA 8 Ohms load both channels driven
Dimensions (H x W x D):	115mm x 440mm x 300mm
Nett Weight (unpacked):	11 kg
Gross Weight (Packed):	13 kg

Exposure Warranty Policy

1. The Exposure warranty entitles you to FREE repair of this unit for the first three (3) years from the date of purchase.
2. This warranty is valid only if the unit is purchased from an authorised Exposure dealer, registered with the authorised agent in your country of residence and issued with a recognised warranty card.
3. The agent accepts no responsibility for defects arising from accident, misuse, abuse, wear and tear, neglect or through unauthorised adjustment and/or repair or replacement of any components, nor will they accept responsibility for damage or loss occurring during transit to or from the person making a claim under the warranty.
4. The Exposure warranty covers:
 - Parts and labour costs for three (3) years from the date of purchase. Please retain your original receipt as proof of purchase and purchase date. The guarantee is extended only to the original purchaser and is not transferable.

When making claims under this warranty:

1. The equipment should be suitably packed and returned to the dealer from whom it was purchased, or directly to the local distributor, together with proof of purchase or a copy of the dated sales receipt.
2. If necessary the unit should be sent carriage pre-paid by a reputable carrier – NOT by post.
3. No responsibility is accepted for the unit whilst in transit to the dealer or agent, and customers are advised to insure the unit against loss or damage whilst in transit.
4. The warranty card MUST be produced when making claims against this guarantee.
5. Any tampering or alteration made to the warranty card or to the serial number on the equipment will invalidate the warranty.
6. The dealer or the agent shall notify the customer when the repairs have been completed. The customer must claim the goods within fourteen days from the date of notice, failing which, the Company reserves the right to impose storage charges.
7. The Company reserves the right to dispose of the equipment after 90 days from the date of notice in a manner that it sees fit and without compensation to the customer.